



Situata immediatamente a ridosso del Porto di La Spezia, terzo in Italia per la movimentazione delle merci e importantissimo punto di accesso per le vie del centro-nord Europa, nonché sede di storici cantieri navali, MICROTEM progetta e realizza da anni tenute meccaniche e sistemi di tenuta.

Proprio per la vicinanza con il porto ci ha dato la possibilità di riparare e ricondizionare a nuovo tenute meccaniche per assi elica proveniente da tutto il mondo e installate su imbarcazione di ogni tipologia, dai pattugliatori delle forze dell'ordine alle grandi navi transoceaniche, sino alle navi da crociera.

Dopo aver fatto bagaglio delle esperienze in questo settore, MICROTEM ha sviluppato un prodotto che potesse sopprimere a tutte le "failures" delle tenute meccaniche assi elica esistenti.

La serie MTM901, progettata e realizzata dal diametro 20 mm (0.75 inches) sino al diametro 185 mm (7.3 inches), è un prodotto innovativo che assicura una elevata capacità di compensazione ai disallineamenti angolari (fino a 2° gradi), al movimento assiale (fino a 20 mm) e al movimento radiale (fino a 10 mm).

Realizzata con materiali all'avanguardia, si propone come prodotto ad elevatissima affidabilità. Grazie al suo design compatto, risulta di facile installazione, dando la possibilità ai progettisti di ridurre al massimo lo spazio nella sala macchine, dedicato al sistema di tenuta della propulsione.

Grazie alla tecnologia di simulazione FEM e ai numerosi test compiuti, sia in laboratorio che direttamente in mare aperto, abbiamo potuto realizzare particolari geometrie degli anelli striscianti, capaci di realizzare un bassissimo coefficiente di attrito e quindi un ridotto sviluppo di calore che assicura che la tenuta meccanica serie MTM901, riesca a d arrivare a performance superiori alle 25.000 ore di funzionamento.

La serie MTM901 prevede differenti soluzioni in cui è prevista l'integrazione del watershield (MTM902), oppure in cui le parti di contatto vengono realizzate in due metà (MTM903).

L'Ufficio Tecnico è in grado di "customizzare" il design standard della serie MTM901 per adattarla alle varie necessità dei cantieri.

Grazie alla configurazione a "cartuccia" la tenuta meccanica arriva già pronta per l'installazione e l'operatore non deve preoccuparsi di dover calcolare difficoltose misure, azzerando così il rischio di errori di montaggio.

Il Kit di manutenzione (repair kit), sempre disponibile pronto a magazzino, garantisce una riduzione del tempo di intervento e del costo che fanno delle MTM901 un prodotto da scegliere per la serenità delle vostre vacanze.

Located just close to the Port of La Spezia, third Italian main port in the movement of goods and important access point to north-central Europe and home of historical shipyards, MICROTEM design and manufactures mechanical seals and mechanical seal systems.

Its proximity to the port gave us the opportunity to repair and recondition mechanical seals for propeller shafts coming from all over the world and installed on boats of all types, from law enforcement patrol boats to large ocean-going vessels, up to cruise ship.

After having gained experience in this field, MICROTEM has developed a product that could compensate for all the "failures" of all existing mechanical seals for propeller shafts.

The series MTM901, designed and produced from the diameter 20 mm (0.75 inches) to the diameter 185 mm (7.3 inches), is an innovative product that provides high capacity to compensate for angular misalignment (up to 2° degrees), for axial movement (up to 20 mm) and for radial movement (up to 10 mm).

Made from advanced materials, it is a product with a very high reliability. Thanks to its compact design, is easy to install, giving to designers the possibility to minimize the space in the engine room, dedicated to the sealing system of propulsion.

Thanks to the technology of FEM simulation and to the numerous tests done, both in the laboratory and directly in the open sea, we were able to achieve a particular geometry of the sliding rings, able to develop a very low coefficient of friction and then a low heat development that ensures that the MTM901 series manages to get superior performance at 25,000 hours of operation.

The series MTM901 provides different solutions with the "WaterShield" (MTM902) or where the contact parts are made of two halves (MTM903).

The technical office is able to "customize" the standard design of the MTM901 series to fit the various need of the shipyards.

Due to the "cartridge" configuration the mechanical seal is already ready for the installation and the operator does not han to worry about having to calculate difficult measures, thus eliminating the risk of installation errors.

The kit of maintenance (repair kit), always available in stock, warrants a reduction of both operating time and cost, making the MTM901 a product to choose for the serenity of your holidays.

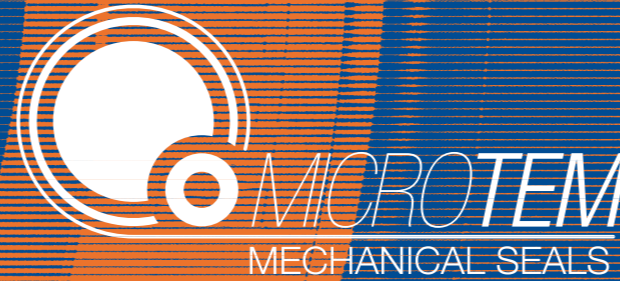
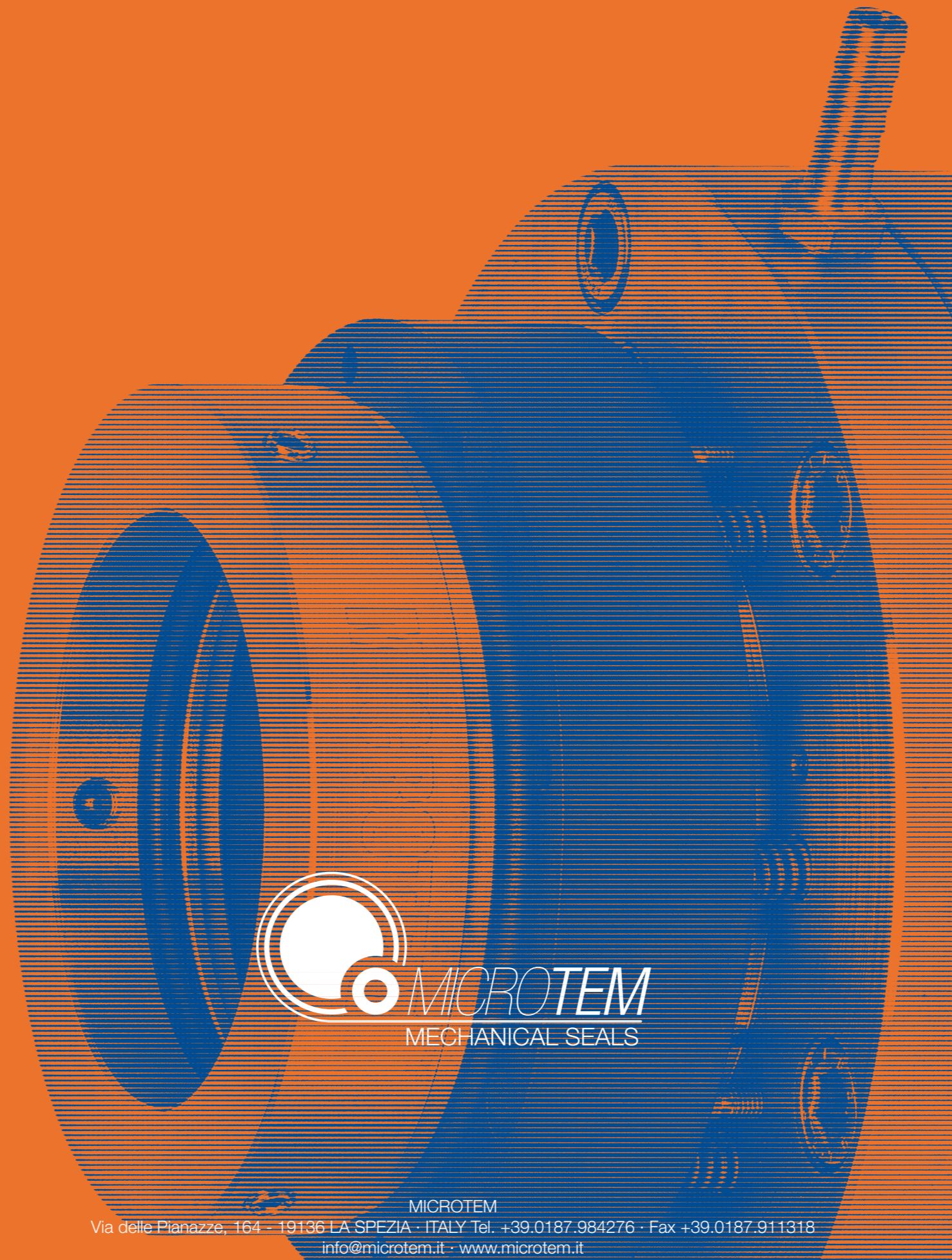

MICROTEM
Via delle Pianazze, 164 - 19136 LA SPEZIA - ITALY Tel. +39.0187.984276 - Fax +39.0187.911318
info@microtem.it · www.microtem.it



COMPONENTS & SOLUTIONS FOR FLUID HANDLING



MM 901
SERIES



TENUTE SETTORE NAVALE
MECHANICAL SEALS FOR NAVAL SECTOR

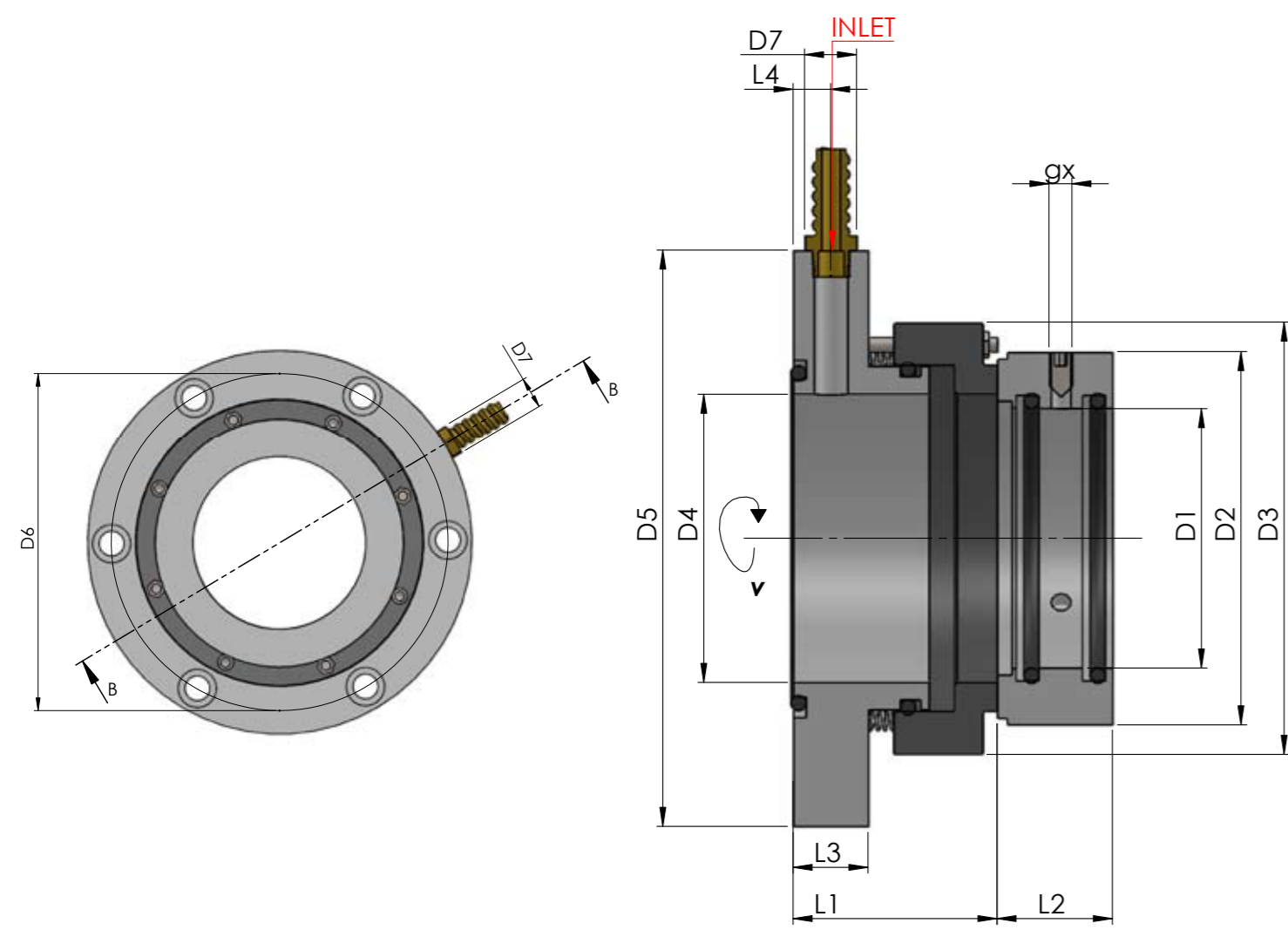

TIPO	D1 (H7)	D2	D3	D4	D5	D6	D7	L1	L2	L3	L4
MTM901/0200	20	70	80	30	130	105	1/4"	87	40	26	13
MTM901/0250	25	75	85	35	135	110	1/4"	87	40	26	13
MTM901/0300	30	80	90	40	140	115	1/4"	87	40	26	13
MTM901/0350	35	85	95	45	145	120	1/4"	87	40	26	13
MTM901/0400	40	90	100	50	150	125	1/4"	87	40	26	13
MTM901/0450	45	95	105	55	155	130	1/4"	87	40	26	13
MTM901/0500	50	100	110	60	160	135	1/4"	87	40	26	13
MTM901/0550	55	105	115	65	165	140	1/4"	87	40	26	13
MTM901/0600	60	110	120	70	170	145	1/4"	87	40	26	13
MTM901/0650	65	115	125	75	175	150	1/4"	87	40	26	13
MTM901/0700	70	120	130	80	180	155	1/4"	87	40	26	13
MTM901/0750	75	125	135	85	185	160	1/4"	87	40	26	13
MTM901/0800	80	130	140	90	190	165	1/4"	87	40	26	13
MTM901/0850	85	135	145	95	195	170	1/4"	87	40	26	13
MTM901/0900	90	140	150	100	200	175	1/4"	87	40	26	13
MTM901/0950	95	145	155	105	205	180	1/4"	87	40	26	13
MTM901/1000	100	150	160	110	210	185	1/4"	87	40	26	13
MTM901/1100	110	160	170	120	220	195	1/4"	97	50	36	23
MTM901/1200	120	170	180	130	230	205	1/4"	97	50	36	23
MTM901/1300	130	180	190	140	240	215	1/4"	97	50	36	23
MTM901/1400	140	190	200	150	250	225	1/4"	97	50	36	23
MTM901/1500	150	200	210	160	260	235	1/4"	97	50	36	23

Main Dimensions (mm)

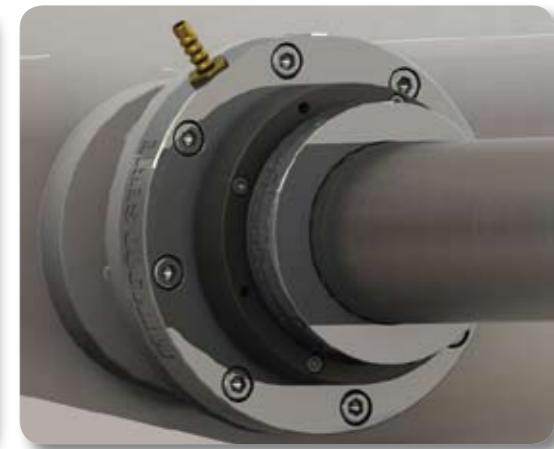
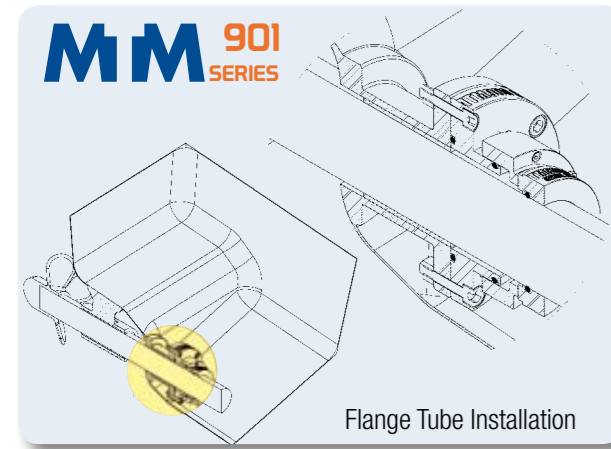
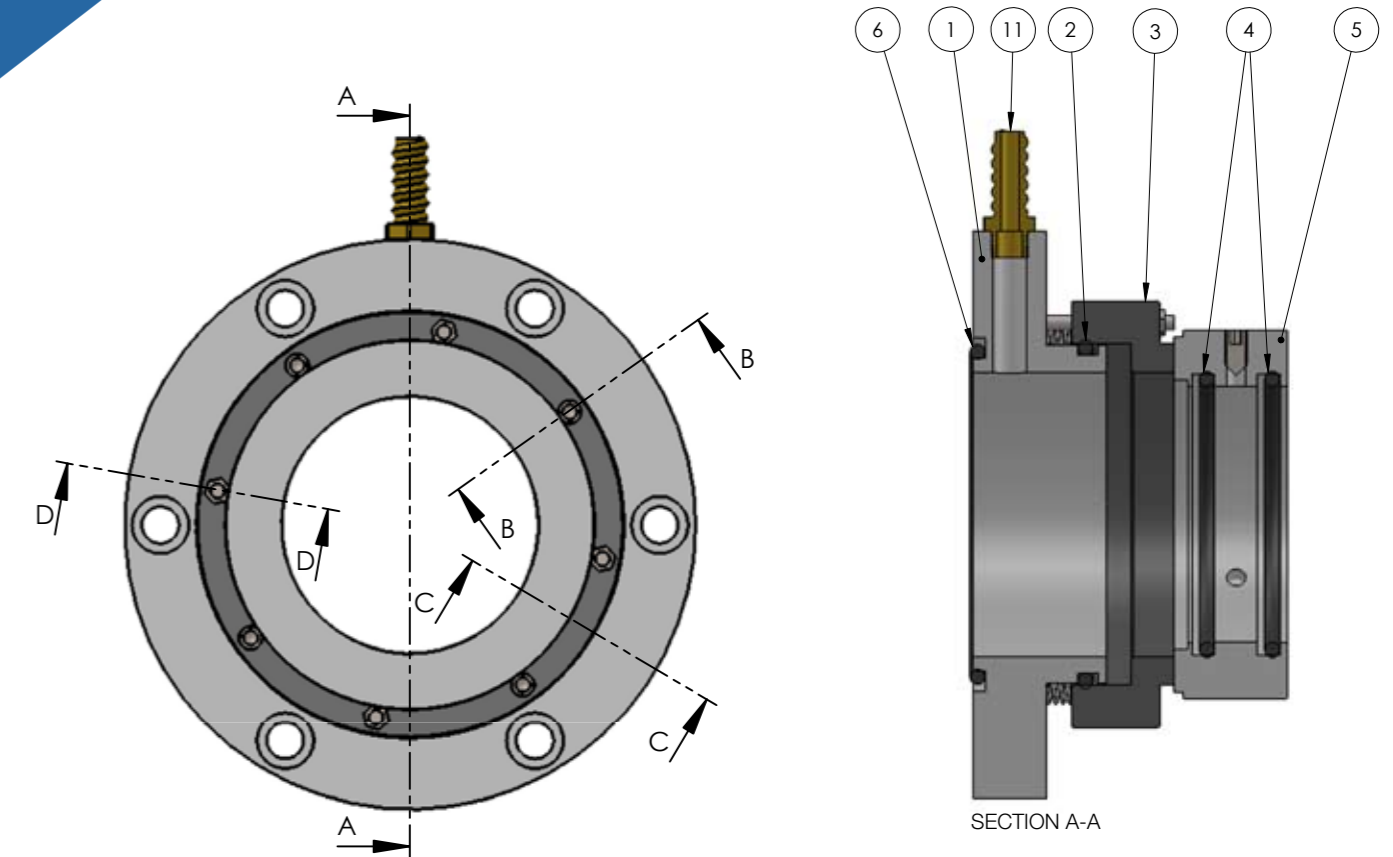
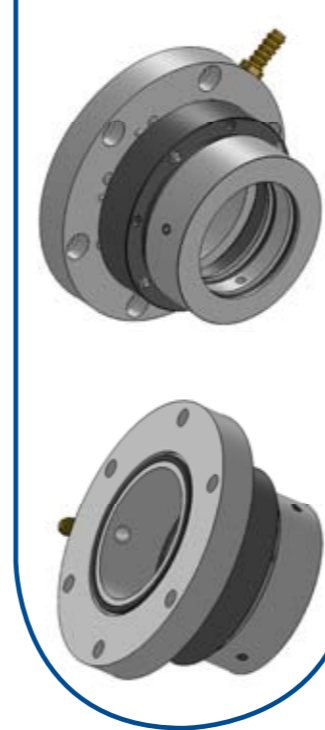

TIPO	D1 (H7)	D2	D3	D4	D5	D6	D7	L1	L2	L3	L4
MTM901/0,75	3/4	2 3/4	3 1/4	1 1/3	5 1/6	4 1/6	1/4	3 1/2	1 1/2	1/4	1/2
MTM901/1	1	2 1/2	3 1/4	1 1/2	5 1/4	3 1/4	1/4	3 1/2	1 1/2	1/4	1/2
MTM901/1,25	1 1/4	2 3/4	3 1/2	1 1/2	5 1/2	3 3/4	1/4	3 1/2	1 1/2	1/4	1/2
MTM901/1,5	1 1/2	3 1/4	3 4/4	1 1/4	5 4/4	4 1/4	1/4	3 1/2	1 1/2	1/4	1/2
MTM901/1,75	1 3/4	3 1/4	4 1/4	2 1/4	6/4	4 1/4	1/4	3 1/2	1 1/2	1/4	1/2
MTM901/2	1 4/4	3 1/2	4 1/4	2 1/4	6 1/4	4 1/2	1/4	3 1/2	1 1/2	1/4	1/2
MTM901/2,25	2 1/4	3 4/4	4 3/4	2 3/4	6 3/4	4 4/4	1/4	3 1/2	1 1/2	1/4	1/2
MTM901/2,5	2 1/2	4 1/4	4 4/4	2 4/4	6 4/4	5 1/4	1/4	3 1/2	1 1/2	1/4	1/2
MTM901/2,75	2 3/4	4 1/4	5/4	3 1/4	7/4	5 3/4	1/4	3 1/2	1 1/2	1/4	1/2
MTM901/3	2 4/4	4 1/2	5 1/4	3 1/4	7 1/4	6/4	1/4	3 1/2	1 1/2	1/4	1/2
MTM901/3,25	3 1/4	4 3/4	5 1/2	3 1/2	7 1/2	6 1/2	1/4	3 1/2	1 1/2	1/4	1/2
MTM901/3,5	3 1/2	5/4	5 4/4	3 4/4	7 3/4	6 4/4	1/4	3 1/2	1 1/2	1/4	1/2
MTM901/3,75	3 3/4	5 1/4	6/4	4 1/4	8/4	6 4/4	1/4	3 1/2	1 1/2	1/4	1/2
MTM901/4	3 4/4	5 1/2	6 1/4	4 1/4	8 1/4	7 1/4	1/4	3 1/2	1 1/2	1 1/2	4/4
MTM901/4,25	4 1/4	5 4/4	6 3/4	4 3/4	8 3/4	7 1/4	1/4	3 1/2	1 1/2	1 1/2	4/4
MTM901/4,5	4 1/2	6/4	6 4/4	4 4/4	8 3/4	7 3/4	1/4	3 1/2	1 1/2	1 1/2	4/4
MTM901/4,75	4 3/4	6 1/4	7/4	5/4	9/4	7 3/4	1/4	3 1/2	1 1/2	1 1/2	4/4
MTM901/5	5/4	6 3/4	7 1/2	5 1/2	9 1/2	8/4	1/4	3 1/2	1 1/2	1 1/2	4/4
MTM901/5,25	5 1/4	6 4/4	7 3/4	5 3/4	9 3/4	8/4	1/4	3 3/4	1 1/4	1 1/2	4/4
MTM901/5,5	5 1/2	7/4	7 3/4	5 4/4	9 3/4	8 1/2	1/4	3 3/4	1 1/4	1 1/2	4/4
MTM901/5,75	5 3/4	7 1/4	8/4	6/4	10/4	8 1/2	1/4	3 3/4	1 1/4	1 1/2	4/4
MTM901/6	5 4/4	7 1/2	8 1/4	6 1/4	10 1/4	8 3/4	1/4	3 3/4	1 1/4	1 1/2	4/4

Main Dimensions (inches)

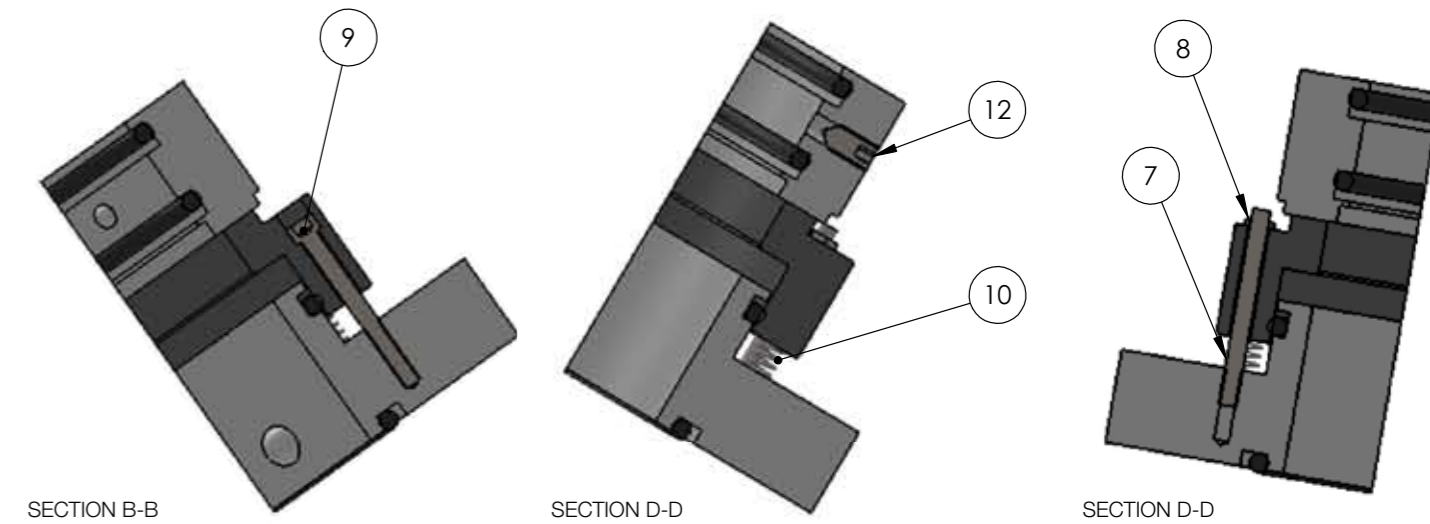

MTM901_Flyer-Rev.02-Jan.2015

Part list				Part list			
POSITION	DESCRIPTION	MATERIAL	QUANTITY	POSITION	DESCRIPTION	MATERIAL	QUANTITY
1	FLANGE	STAINLESS STEEL	1	9	SCREW	STAINLESS STEEL	4
2	O-RING	NBR	1	10	SPRING	STAINLESS STEEL	8
3	STATIONARY RING	CARBON GRAPHITE	1	11	FLEXIBLE PIPE SUPPORT	STAINLESS STEEL	1
4	O-RING	NBR	2	12	GRUB SCREW	STAINLESS STEEL	3
5	ROTARY RING	STAINLESS STEEL	1				
6	O-RING	NBR	1				
7	PRE-LOAD SCREW	STAINLESS STEEL	4				
8	PRE-LOAD NUT	STAINLESS STEEL	4				

Materials: ogni tipo di materiale è disponibile su richiesta · Materials: any type of materials are available on request

- Elevata capacità di compensare vibrazioni scafo/asse elica
- Dispositivo di circolazione dell'acqua
- Elevata capacità di compensare disallineamenti radiali e angolari tra asse elica e passaggio scafo
- High capacity to compensate for vibration hull/propeller shaft
- Water circulation device
- High capacity to compensate for radial and angular misalignment between propeller shaft and hull passage

Tutte le dimensioni possono essere personalizzate su richiesta
Remarks: other shaft sizes (d1) on request · other stern tube sizes (d5) on request · All dimensions can have customizations on request